

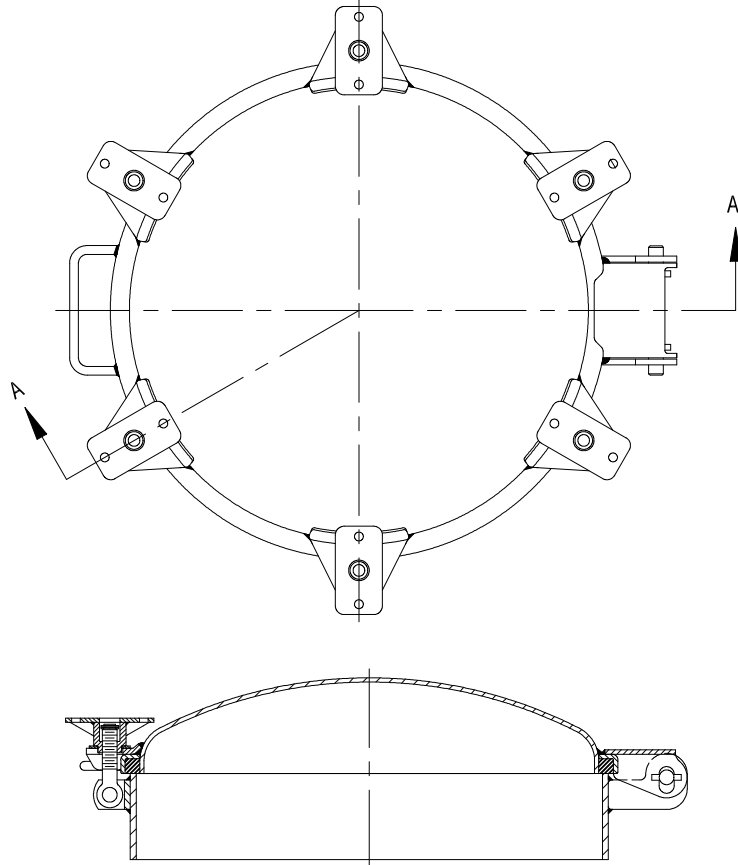

20" (508mm) FULL OPENING MANHOLE

THREADED HOLD-DOWNS

6" OR 10" HIGH COLLAR AVAILABLE



Section A-A  
Model 8355

Tiona 20" Full Opening Manholes are fabricated for greater strength and less weight. Full 20 inch opening assures safe entrance for inspection or cleaning of tank.

Weld Collar	Cover	Wing-Nut, Swing Bolts Hinge Pins	Number Hold Downs	*Working Pressure	Weight	Collar Height	Assembly No.
Aluminum	Steel	Stnls 304	6	50 PSI 3.4 BAR	52lb	6" (152.4mm)	8355ASW-6"
Aluminum	Stnls 316L	Stnls 304			23.6Kg		8355ALW-6"
Steel	Steel	Stnls 304			70lb		8355SCW-6"
Stnls 316L	Stnls 316L	Stnls 304			31.8Kg		8355LCW-6"
Aluminum	Steel	Stnls 304	6	50 PSI 3.4 BAR	38lb	10" (254mm)	8355ASW-10"
Aluminum	Stnls 316L	Stnls 304			26.4Kg		8355ALW-10"
Steel	Steel	Stnls 304			88lb		8355SCW-10"
Stnls 316L	Stnls 316L	Stnls 304			40Kg		8355LCW-10"

Notes: White Hypalon gasket furnished as standard (reference suffix "W" in assembly number). For other gaskets available, see parts page for correct suffix.

\*Tests were conducted and ratings determined with homogeneous gaskets

During installation and welding the collars to the tank, care should be exercised to insure the collars remain flat and round in order to assure proper performance. If necessary a welding fixture should be used to prevent distortion.

PARTS LIST

20" (508mm) FULL OPENING MANHOLE

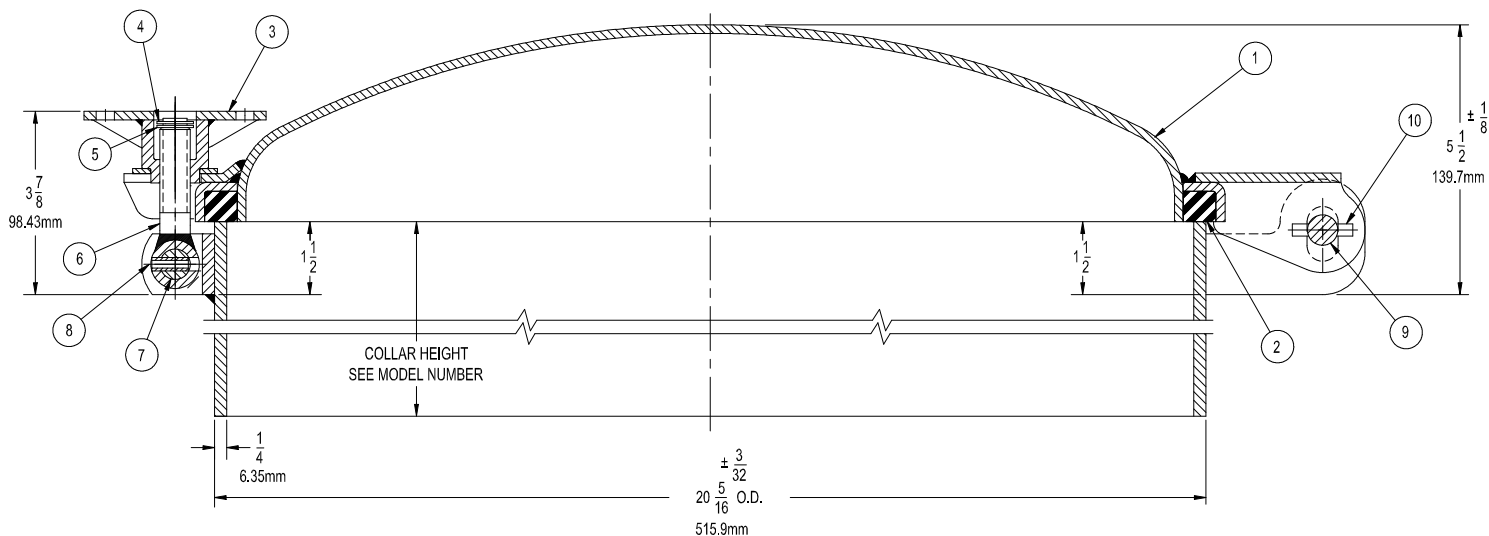

No.	Description	Material	Part No.
1	Cover	Steel	6348FB
		Stnls 316L	6348LC
2	Gasket*	B Buna-N	3513BN
		V Viton	3513VT
		W White Hypalon	3513WH
		E White Non-Asbestos with Teflon Suspensoid (Woven)	3513NT

No.	Description	Material	Part No.
3	Wing Nut	Stnls 304	3576SL
4	Snap Ring	Stnls 304	9Q4933
5	Snap Ring Washer	Stnls 304	3575SL
6	Swing Bolt	Stnls 304	3765SL
7	Swing Bolt Pin	Stnls 304	3086SL
8	Roll Pin-Swg Bolt	Stnls 304	9Q8593
9	Hinge Pin	Stnls 304	3818SL
10	Roll Pin-Hinge Pin	Stnls 304	9Q8594

\*Gasket Maximum Temperature

Buna-N (Nitrile)	250°F
Viton	400°F
White Hypalon	250°F
White Non-Asbestos with Teflon Suspensoid	500°F

GASKETS:

Check the condition of all gaskets and replace if their effectiveness as a seal is impaired in any way. Replacement gaskets must be compatible with products carried.

MAINTENANCE:

Manhole assembly should be inspected with sufficient frequency and with due regard to the products carried to insure a liquid tight closure. Any worn, damaged, or missing parts must be replaced.

WING NUTS AND SWING BOLTS:

All swing bolt and wing nut assemblies must be secured to the cover and tightened to insure the pressure and product retention performance of the manhole assembly.

**WARNING** Use only genuine Betts Industries Inc. replacement parts. Use of substitute parts can impair the proper functioning of this product.