

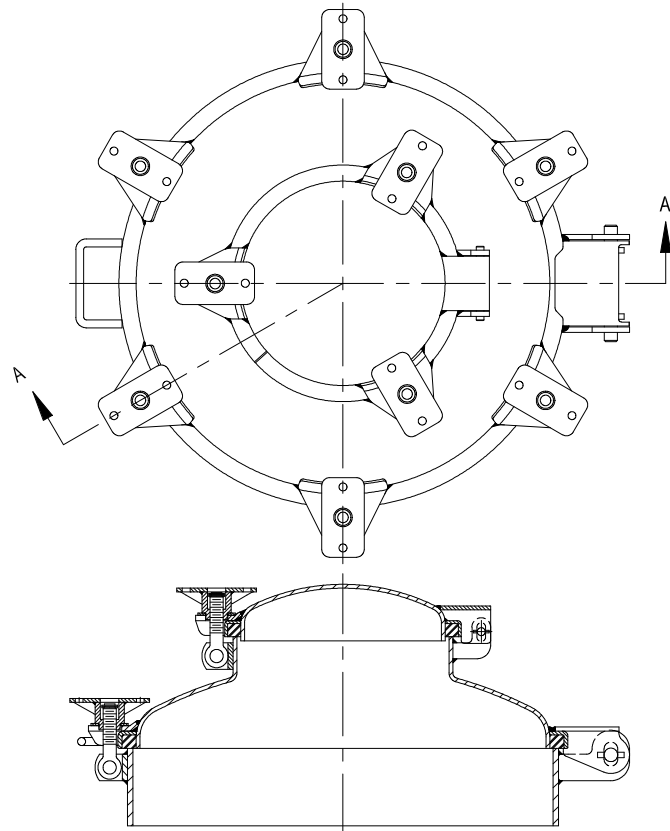

20" (508mm) FULL OPENING MANHOLE

WITH 10" (254mm) FILL
ASME TYPE

ASME SYMBOL & DATA PROVIDED
THREADED HOLD-DOWNS
6" OR 10" HIGH COLLAR AVAILABLE



Section A-A
Model 8387

This Tiona 20" Full Opening Manhole conforms to the requirements of the ASME code for pressure vessels Section VIII, Division 1.

Weld Collar	Cover	Wing-Nut, Swing Bolts Hinge Pins	Number Hold Downs	*Working Pressure	Weight	Collar Height	Assembly No.
Aluminum	Steel	Stnls 304	3 Fill 6 Manhole	50 PSI 3.4 BAR	65.5lb	6" (152.4mm)	8387ASW-6"
Aluminum	Stnls 316L	Stnls 304			29.8Kg		8387ALW-6"
Steel	Steel	Stnls 304			83.5lb		8387SCW-6"
Stnls 316L	Stnls 316L	Stnls 304			37.8Kg		8387LCW-6"
Aluminum	Steel	Stnls 304	3 Fill 6 Manhole	50 PSI 3.4 BAR	71.5lb	10" (254mm)	8387ASW-10"
Aluminum	Stnls 316L	Stnls 304			32.5Kg		8387ALW-10"
Steel	Steel	Stnls 304			101.5lb		8387SCW-10"
Stnls 316L	Stnls 316L	Stnls 304			46.03Kg		8387LCW-10"

Canadian Registration Number OH0724.5621473

Notes: White Hypalon gasket furnished as standard (reference suffix "W" in assembly number). For other gaskets available, see parts page for correct suffix.

*Tests were conducted and ratings determined with homogeneous gaskets

During installation and welding the collars to the tank, care should be exercised to insure the collars remain flat and round in order to assure proper performance. If necessary a welding fixture should be used to prevent distortion.

PARTS LIST

20" (508mm) FULL OPENING MANHOLE
WITH 10" (254mm) FILL
ASME TYPE

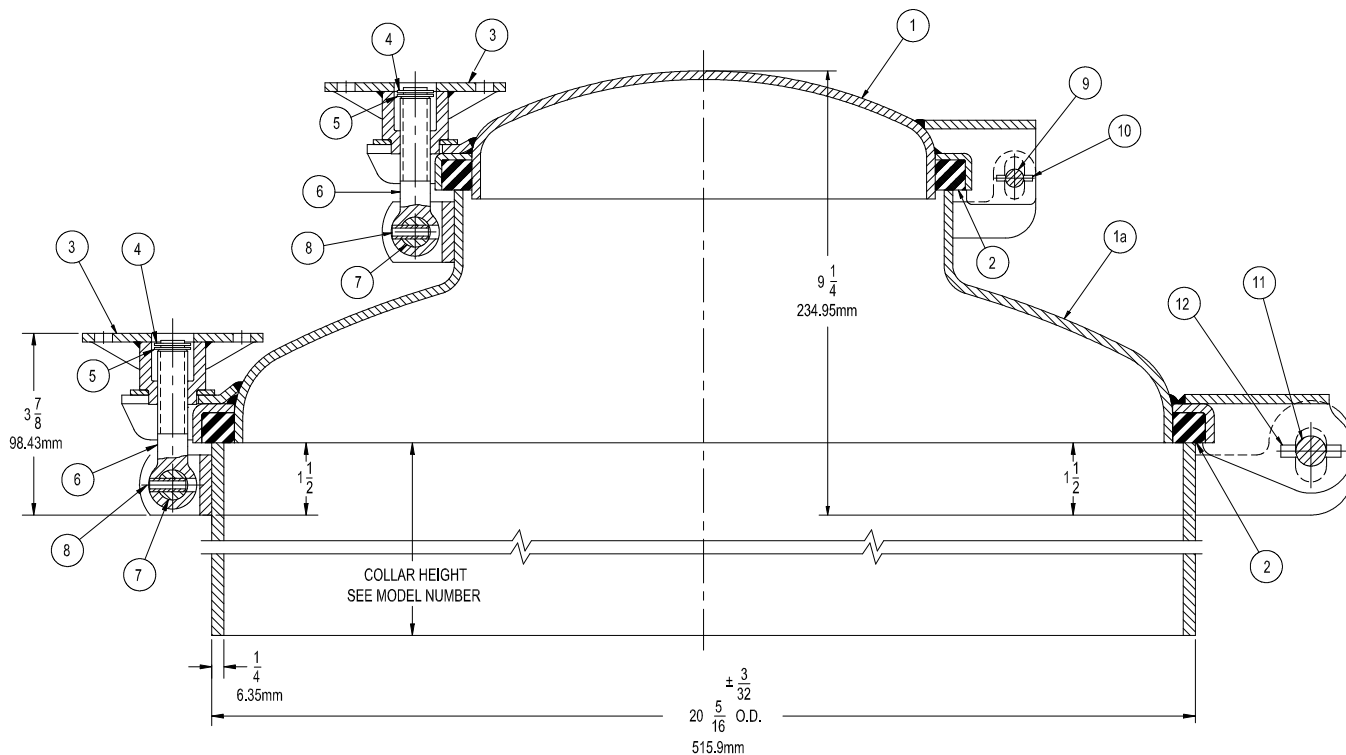

No.	Description	Material	Part No. Fill	Part No. Manhole
1	Cover (3 Hold Downs)	Steel	6411FB	
		Stnls 316L	6411LC	
1a	Cover (6 Hold Downs)	Steel		6414FB
		Stnls 316L		6414LC
2	Gasket*	B Buna-N	3567BN	3513BN
		V Viton	3567VT	3513VT
		W White Hypalon	3567WH	3513WH
		E White Non-Asbestos With Teflon Suspensoid (Woven)	3567NT	3513NT

No.	Description	Material	Part No.
3	Wing Nut	Stnls 304	3576SL
4	Snap Ring	Stnls 304	9Q4933
5	Snap Ring Washer	Stnls 304	3575SL
6	Swing Bolt	Stnls 17/4 PH	4102SF
7	Swing Bolt Pin	Stnls 304	3086SL
8	Roll Pin-Swg Bolt	Stnls 304	9Q8593
9	Hinge Pin	Stnls 304	3618SL
10	Roll Pin-Hinge Pin	Stnls 304	9Q8601
11	Hinge Pin	Stnls 304	3818SL
12	Roll Pin-Hinge Pin	Stnls 304	9Q8594

***Gasket Maximum Temperature**

Buna-N (Nitrile)	250°F
Viton	400°F
White Hypalon	250°F
White Non-Asbestos with Teflon Suspensoid	500°F

GASKETS:

Check the condition of all gaskets and replace if their effectiveness as a seal is impaired in any way. Replacement gaskets must be compatible with products carried.

MAINTENANCE:

Manhole assembly should be inspected with sufficient frequency and with due regard to the products carried to insure a liquid tight closure. Any worn, damaged, or missing parts must be replaced.

WING NUTS AND SWING BOLTS:

All swing bolt and wing nut assemblies must be secured to the cover and tightened to insure the pressure and product retention performance of the manhole assembly.

WARNING Use only genuine Betts Industries Inc. replacement parts. Use of substitute parts can impair the proper functioning of this product.