

# LIFT CHECK P-728

## ALUMINUM

Dry Bulk Transports • Tank Trucks • 125 psi WOG †@ 100°F  
25 psi @ 350°F • Spring Loaded  
Composition Disc  
Threaded Ends



Vibration-proof disc construction, Viton-A\* renewable disc assures tight close at high temperature operation. Stainless poppet stem and disc retainer, guided top and bottom in friction free bushings.

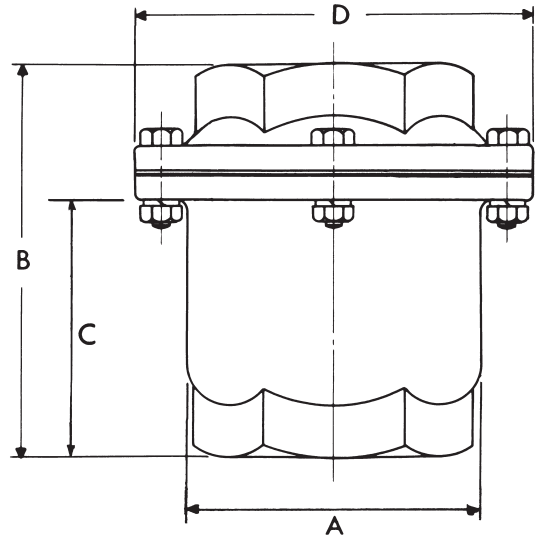

### DIMENSIONS-INCHES

SIZE	A	B	C	D
3	5	6 3/4	4 9/16	6 3/4

†Non-Shock

\*Registered E.I. DuPont Trademark