

ANGLE LIFT CHECK P-717F

ALUMINUM

125 psi WOG at 100°F • 25 psi WOG at 350°F

Square Bolted Cap • Square Flange

Lightweight, positive closing, Viton-A* renewable disc. Stainless steel poppet stem and disc retainers. Guided top and bottom in friction free bearings.

NOTE: This valve was formerly identified by drawing number C-35417-F.

Valve must be mounted in upright position.

For 2" Threaded Bronze Angle Check see P-717S.

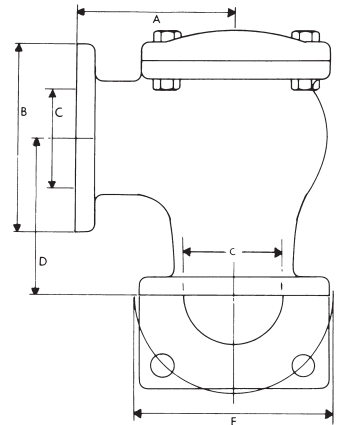
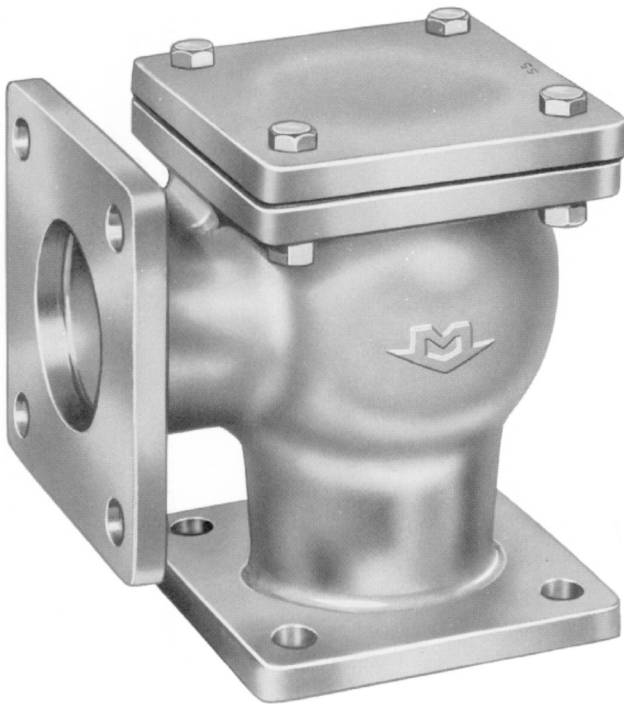

DIMENSIONS-INCHES

Size	A	B	C	D	E
2 1/2	4	4 3/4	2 1/2	4	5

CAP FLANGE SPECIFICATIONS-INCHES

Size	FLANGE	BOLT DIA.	NO. BOLTS
2	4 3/4 Sq.	3/8	4

*Registered E.I. DuPont Trademark