

SWING CHECK P-2519A

ALUMMINUM

Dry Bulk Transports • Tank Truck
Aluminum Disc With Viton® Seat
150 WOG †

A rugged multi-purpose swing check for general tank and loading rack installations. All the advantages of full flow afforded by swing check design, near silent operation, leak resistance and quick cap removal; stainless steel pin and plugs.



MODEL P-2519A-3"

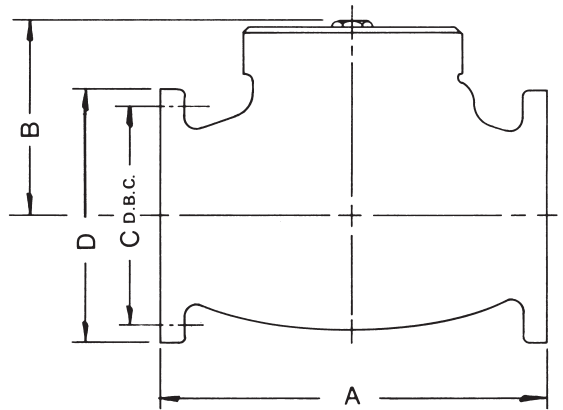

DIMENSIONS-INCHES

SIZE	A	B	C	D	E	F
3	6 7/8	4 1/16	5	4 3/4	4	9/16

DIMENSION DESCRIPTION

C	Diameter Bolt Circle
D	For 3" Square Flange
E	Number of Bolt Holes
F	Size of Bolt Holes

† Non-Shock