

BUTTERFLY P-2855E , P-2855H ALUMINUM

Tank Trucks • Bulk Plants • Dry Bulk Plants
90° Arc • Quick Open

Lightweight aluminum accepts a variety of flanged fittings developed specifically for Tank Truck applications.

MODEL 2855E has an EPDM liner that is for dry bulk product and airlines.

MODEL 2855H has an HYDRIN liner that is for use with petroleum products.

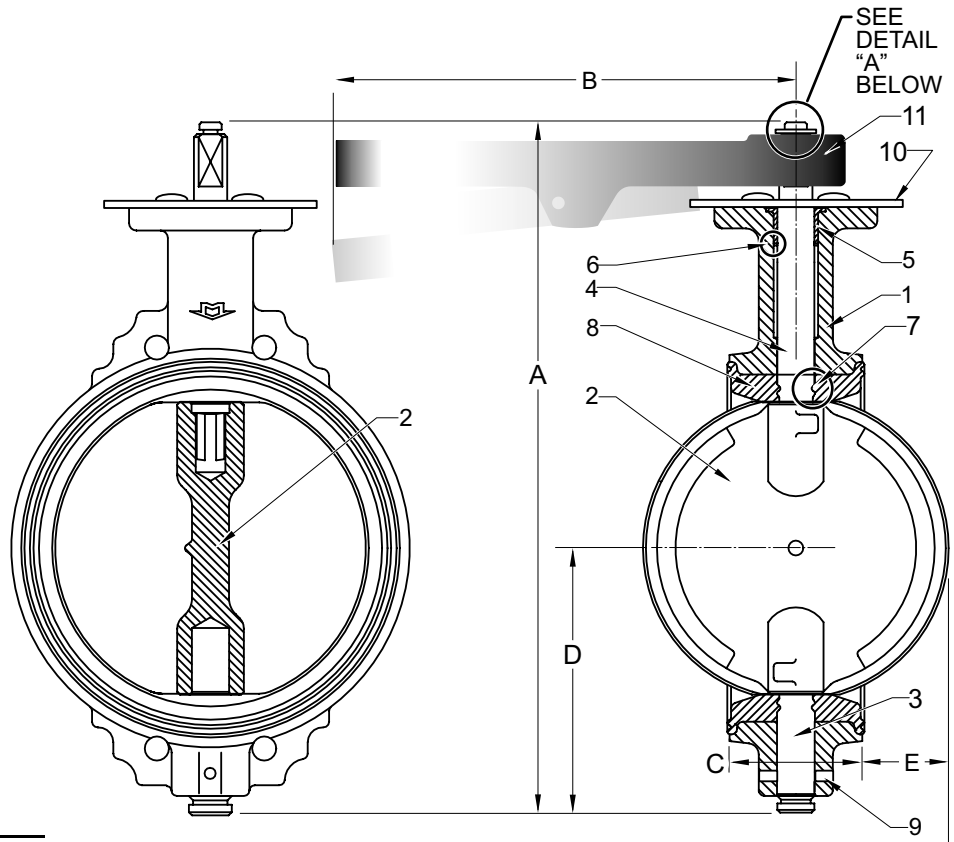

MATERIALS LIST

ITEM	PART NAME	MATERIALS
1	Body	Aluminum
2	Disc	Ductile Iron Ni-Plated
3	Bottom Stem	Stainless Steel T-416
4	Top Stem	Stainless Steel T-416
5	Top Bearing with Integrated Dirt Seal	Thermo Setting Alloy
6	C-Clip	Spring Steel
7	Stem Seal	EPDM
8	Liner	EPDM
9	Spring Pin	Stainless Steel T-302
10	Stop Plate	Carbon Steel Zinc Plated
11	Handle	Cast Iron
12	Crimp Ring	Stainless Steel T-309

VALVE DIMENSIONS

	2"	3"	4"	5"	6"
A	8.15	9.25	10.52	11.60	12.5
B	9	9	11	11	11
C	1.62	1.74	1.99	2.24	2.31
D	2.90	3.52	4.01	4.68	4.78
E	0.30	0.72	1.10	1.46	2

DETAIL "A"

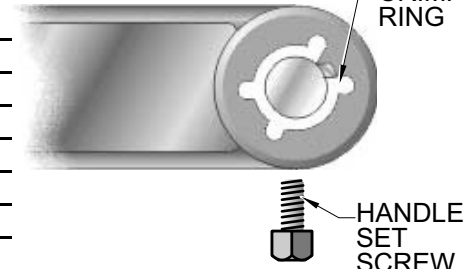

FLANGE SPECIFICATIONS

PIPE SIZE	ASA			T.T.M.A.			COMPETITIVE		
	B.C. DIA.	BOLT DIA.	NO. BOLTS	B.C. DIA.	BOLT DIA.	NO. BOLTS	B.C. DIA.	BOLT DIA.	NO. BOLTS
2	4 3/4	5/8	4	3 3/4	3/8	6	4 17/64	3/8	4
3	6	5/8	4	4 7/8	3/8	8	4 29/32	3/8	6
4	7 1/2	5/8	8	5 7/8	3/8	8	7 1/32	1/2	6
5	8 1/2	3/4	8	7	3/8	12	7 9/16	1/2	6
6	9 1/2	3/4	8	8 1/8	3/8	12	8 15/16	1/2	6